



# Low-Pressure Pipe Systems

Project funded by the U.S. Environmental Protection Agency under Assistance Agreement No. CX824652

## What is a low-pressure pipe system?

A low-pressure pipe (LPP) system is a shallow, pressure-dosed soil absorption system with a network of small diameter perforated pipes placed in narrow trenches. Originating in North Carolina and Wisconsin, LPP systems were developed as an alternative to conventional soil absorption systems to eliminate problems such as: clogging of the soil from localized overloading, mechanical sealing of the soil trench during construc-

on. The level controls are set for a specific pumping sequence of one to two times daily, allowing breaks in between doses for the soil to absorb the wastewater. However, the dosing mechanisms and frequency may vary for different systems.

The pump moves the effluent through the supply line and manifold to the distribution laterals under low pressure. The laterals are a network of PVC pipes that have small, drilled holes through which the wastewater is distributed evenly. The laterals are placed in narrow trenches that allow enough storage

volume so that the depth of the wastewater does not exceed 2 or 3 inches of the total trench depth during each dosing cycle.

## What are the advantages and

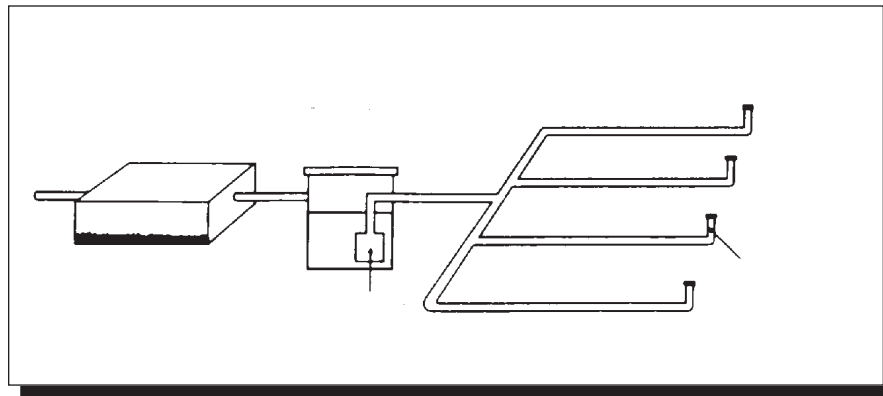

**Figure 1: Low-Pressure Pipe System**

Source: U.S. Environmental Protection Agency (1992)

tion, anaerobic conditions due to continuous saturation, and a high water table. The LPP system has the following design features that overcome these problems: 1) shallow placement, 2) narrow trenches, 3) continuous trenching, 4) pressure-dosed with uniform distribution of the effluent, 5) design based on areal loading, and 6) resting and re-aeration between doses.

The main components of an LPP system are:

- a septic tank or an aerobic unit;
- pumping (dosing) chamber (submersible effluent pump, level controls, high water alarm, and supply manifold); and
- small diameter distribution laterals with small perforations (holes).

The septic tank is where settleable and floatable solids are removed and primary treatment occurs. Partially clarified effluent then flows by gravity to a pumping chamber where it is stored until it reaches the level of the upper float control, which turns the pump

## disadvantages of using LPPs?

### Advantages

- Shallow placement of trenches in LPP installations promotes evapotranspiration and enhances growth of aerobic bacteria.
- Absorption fields can be located on sloping ground or on uneven terrain that would otherwise be unsuitable for gravity flow systems.
- Improved distribution through pressurized laterals disperses the effluent uniformly throughout the entire drainfield area.
- Periodic dosing and resting cycles enhance and encourage aerobic conditions in the soil.
- Shallow, narrow trenches reduce site disturbances and thereby minimize soil compaction and loss of permeability.
- LPPs allow placement of the drainfield area upslope of the home site.
- LPPs have reduced gravel requirements.
- There is a significant reduction in land

This fact sheet was developed by Clement Solomon, Peter Casey, Colleen Mackne, and Andrew Lake.

©1998 by the National Small Flows Clearinghouse

area required for the absorption system.

- Costs are comparable to other alternative distribution systems.
- LPPs overcome the problem of peak flows associated with gravity-fed conventional septic systems.

#### Disadvantages

- In some cases, the suitability could be limited by soil, slope, and space characteristics of the location.
- There is a potential for clogging of holes or laterals by solids or roots.
- LPPs have limited storage capacity around their laterals.
- There is the possibility of wastewater accumulation in the trenches or prolonged saturation of soil around orifices.
- LPPs could experience moderate to severe infiltration problems.
- Regular monitoring and maintenance of the system is required; lack of maintenance is a sure precursor to failure.

#### What determines the performance of an LPP system?

Two critical factors that affect the performance of an LPP system are dosing and distribution of the effluent. The dosing and resting periods help maintain aerobic conditions in the soil and around the distribution trench. An LPP system cycles back and forth between aerobic and anaerobic conditions.

The distribution of wastewater must be uniform (spread evenly over the soil absorption field) without hydraulically overloading it.

The four factors that affect the suitability of an LPP system for a given site are soil, slope, available space, and anticipated waste flow. An LPP system should be located in soils that have suitable texture, depth, consistence, structure, and permeability, according to state/local regulations.

Although the size requirements for an LPP system will vary depending on the site, in general an undeveloped lot smaller than 1 acre may not be suitable for an LPP system.

#### Are LPP systems easy to operate and maintain?

A properly designed and installed LPP system requires very little ongoing maintenance. However, regular monitoring is necessary to ensure proper performance. Some states, such as North Carolina, require professionally trained operators to inspect and maintain LPP systems on a minimum of a 6-month frequency.

The septic tank and pumping chamber should be checked for sludge and scum buildup and pumped as needed. Screens or filters can be used to prevent solids from escaping the septic tank.

An important operation and maintenance consideration is that LPP systems are very susceptible to hydraulic overloading due to excess infiltration of rainwater, shallow perched soil waters, and/or groundwater into the tanks. In areas with improper drainage, leaky pump tanks can become sinks for nearby groundwater and can overload the drainfield with more water than the soil can absorb. Therefore, it is important that tanks be watertight to overcome this potential problem.

#### What is the cost of an LPP system?

The cost of LPP systems depends on the contractor, the manufacturers, the site, and the characteristics of the wastewater. The annual operating costs for LPPs include power con-

sumption for the pumps, pipe and other miscellaneous equipment repair, replacement of the components, and monitoring costs for a professional operator.

In a 1989 study of LPP use among different counties in North Carolina, it cost an average of \$2,600 to install an LPP system for a three-bedroom house. The average installation cost across counties ranged from \$1,500 to \$5,000 and was inversely related to the extent of LPP use within a county. Thus, the more LPP systems that are installed within a community, the less the cost per system.

#### How do I stay informed about LPP technology?

For more information on low-pressure pipe systems contact the National Environmental Services Center (NESC) at West Virginia University, Morgantown, WV 26506-6064. Phone: (304) 293-4191. Web site: <http://www.nesc.wvu.edu>.

#### References

- Amoozgar, A.; E. W. West; K. C. Martin; and D. F. Weymann. Dec. 11–13, 1994. "Performance Evaluation of Pressurized Subsurface Wastewater Disposal Systems." On-Site Wastewater Treatment: Proceedings of the Seventh International Symposium on Individual and Small Community Sewage Systems. Atlanta, Georgia.
- Hoover, M. T. and A. Amoozgar. Sept. 18–19, 1989. "Performance of Alternative and Conventional Septic Tank Systems." Proceedings of the Sixth Northwest On-Site Wastewater Treatment Short Course. University of Washington. Seattle, Washington. pp. 173–203.
- Hoover, M. T.; T. M. Disy; M. A. Pfeiffer; N. Dudley; and R. B. Mayer. 1995. *On-Site System Operation and Maintenance Operators Manual*. The National Environmental Training Center for Small Communities (NETCSC). West Virginia University. Morgantown, West Virginia.
- Uebler, R. L. 1982. "Design of Low-Pressure Pipe Wastewater Treatment Systems." 1982 Southeastern On-Site Sewage Treatment Conference Proceedings. North Carolina Division of Health Services and the Soil Science Department. North Carolina State University.
- U.S. Environmental Protection Agency (EPA). May 1992. "Small Wastewater Systems: Alternative Systems for Small Communities and Rural Areas." EPA Office of Water. 830/F-92/001.

*The mention of trade names or commercial products does not constitute endorsement or recommendation for use by the NESC or U.S. EPA.*