



How To Begin a Fire Hydrant Operation and Maintenance Program

Story and photos by **Larry Rader**,
NDWC Environmental Consultant

The single most important thing about having fire hydrants is that they advertise “Fire Protection!” Communities expect that at a moment’s notice, day or night, in any weather, the hydrant will supply sufficient water to extinguish a fire.

A Short Hydrant History

Around the time of the American Revolution, several communities in the U.S. built water distribution systems. These early systems used main lines that workers built using bored-out logs, which they fitted together then buried. When fire fighters needed water, they uncovered the wooden line and bored a hole in the pipe wall. They used the water that collected around the pipe for fighting the fire.

When the fire fighters eventually put the fire out, they drove a tapered wooden plug into the hole in the pipe wall and marked the location of the hole with the “fireplug.” Later, when cast iron became the material of choice for water lines, it became harder to bore the hole. However, water systems installed tees with wooden plugs at convenient locations and the wooden fireplug continued for several more years.

The hydrant’s evolution included a standpipe that fire fighters shoved into the tee after they removed the fireplug. It conveyed water above ground to a hose connection and a ball valve, and it finally made the wooden plug obsolete. It also became the forerunner of the dry-barrel compression hydrant.

In addition, communities may use fire hydrants for things other than putting out fires. In the summer 2002 issue of *On Tap*, I addressed using of hydrants for distribution line flushing. But, the primary reason you install and maintain fire hydrants is to provide your customers with fire protection for their homes and businesses.

Hydrant Types and How They Work

Fire hydrants come in two basic categories: wet-barrel and dry-barrel. Manufacturers intend wet-barrel hydrants to be used only in climates where the temperature never drops below 32 degrees because they are always charged with water. Dry-barrel hydrants automatically drain after the water is turned off and are much more widely used for obvious reasons.

Each manufacturer of dry-barrel hydrants has its own method of operation, but the basics are similar. These hydrants are pressurized and drain through a main valve in the base. When the main valve is opened, the barrel is pressurized. When the main valve is closed, the barrel drains. The main valve is located below the normal frost line to protect the hydrant from freezing, allowing the drybarrel hydrant to be used almost anywhere.

Compression Type: In this type of hydrant, the main valve moves jointly on a vertical axis against a seat located in the hydrant base. The valve moves against the seat to close and away from the seat to open. A vertical stem moves up or down when the operating nut is rotated. The valve may be located below the seat and opens against the pressure or above the seat and opens with the pressure. (See Figure 1 on page 3.)

Other types of dry-barrel hydrants include slide gate and toggle, which describes the mechanics that open and close them, and flush hydrants,

Inspect Hydrants Regularly

which are installed in a pit and have nothing projecting above ground.

The method of allowing the hydrant to drain when closed is equally as important as the method of charging it. Most dry-barrel designs use weep holes, or drains, located at the bottom of the hydrant and below ground level. As the hydrant is turned on, seals are manipulated to close the weep holes, keeping water from being forced out under pressure. As the hydrant is closed, the seals are manipulated away from the weep holes, and the barrel drains.

Each hydrant manufacturer has its own design for almost every operation. The more brands, series, and designs you have in your system, the more complicated your operation and maintenance (O&M) program will become, and the more repair parts and specialized tools you will need to stock. So keep it simple, find a style, brand, or model you like and stick with it.

Operation and Maintenance

Like any other piece of equipment, if you don't operate and maintain your fire hydrants properly, they won't work when you need them most.

Operation: Under normal conditions, the water in your distribution system moves at a fairly constant rate and pressure. Opening a hydrant too quickly could create negative pressure and set up a dangerous backflow situation. Closing a hydrant too quickly can cause water hammer, which is very destructive to lines and equipment. Water hammer is sort of like running headlong into a brick wall. You will immediately wish you had slowed down more gradually.

Dry-barrel hydrants should always be opened fully because the drain mechanism operates with the main valve. A partially opened hydrant can cause water to be forced out through the drains and cause erosion around the base of the hydrant.

However, tightening the caps too soon can trap water in the barrel and set up the possibility of freezing. As a matter of fact, because hydrants need a supply of air to drain properly, a good way to check the drain is to place your hand over an open nozzle



1. Loosen the hold-down nut.



2. Remove the hold-down nut.



3. Loosen the operating nut.



4. Remove the operating nut.



5. Remove the bonnet.



Use a tarp to keep parts clean and from being lost in the mud.



6. Use the manufacturer's seat wrench to unscrew the seat ring.



7. Lift out the entire valve, seat, and stem assembly.

after the hydrant is turned off. As the water drains it creates a vacuum that can be felt at the nozzle. So remember: never tighten the caps until the hydrant finishes draining. And never, ever operate a fire hydrant with any wrench other than the one designed for that particular hydrant.

Inspection: The American Water Works Association (AWWA) recommends all hydrants be inspected regularly, at least once a year. In freezing weather, dry-barrel hydrants may need to be inspected in spring and fall. But for the most part, much of hydrant inspection is visual and common sense. For example:

1. Make sure the hydrant, including all valves and nozzles, is accessible with no obstructions.
2. Check with a listening device for main valve leaks.
3. Use a chalked cord or plumb bob to check for water standing in the barrel.
4. Loosen the cap and open the hydrant a few turns to allow air to vent, and then tighten the cap and open the hydrant fully. All caps must be tight at this point.
5. Make sure the hydrant is turned on fully and check for any leaks around the operating stem, nozzles, any seals or packing, and at the flanges. Replace the O-rings if necessary.
6. Partially close the hydrant until the drains open and flush the drains for a few seconds under pressure.
7. Exercise the watch valve and leave it open.
8. Perform hydrant inspection during line flushing and flow testing, which were discussed in the summer 2002 issue of *On Tap*.
9. And last, but certainly not least, if during the inspection you discover a hydrant that is not working or has major problems, tag it, notify the fire department immediately, and make preparations to fix the problem.

Note: Each time you remove a hydrant's parts, pay special attention to all seals and threads, and note any wear. Most manufacturers recommend that these parts be lubricated before putting the hydrant back together to ensure its smooth operation.

General Maintenance and Repairs

Because of the many different brands and models, always refer to the manufacturer's literature for maintenance items and repair procedures. The manufacturer, or its representative, also can tell you what tools are necessary to perform repairs, such as removing the main valve stem or maintaining other parts of the hydrant. Hydrant repair requires specialized tools. Do not start a project without them.

Dry Barrel Compression Type Hydrant

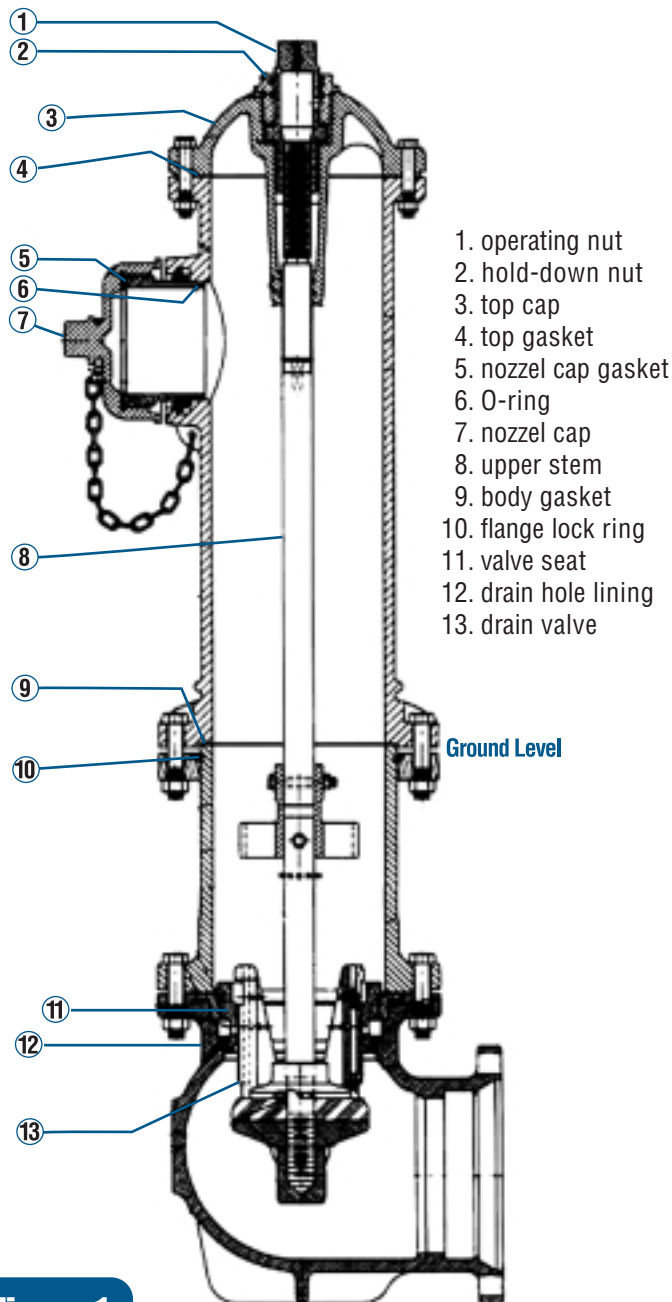

1. operating nut
2. hold-down nut
3. top cap
4. top gasket
5. nozzle cap gasket
6. O-ring
7. nozzle cap
8. upper stem
9. body gasket
10. flange lock ring
11. valve seat
12. drain hole lining
13. drain valve

Ground Level

Figure 1

Source: www.clowcanada.com

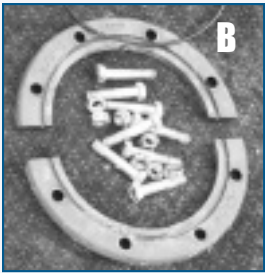

Valve stem with a safety stem coupling (A). This coupling, along with the safety flange and safety bolts & nuts (B), allow the hydrant to be broken off, as in a car accident, without causing the valve to be disturbed and water escaping.



Dismantle the main valve, upper valve plate, and seat ring.



As the hydrant is closed, the upper valve plate slides up and uncovers the weep holes, allowing the hydrant to drain. As the main valve is forced away from the seat ring, the upper valve plate moves down to seal off the drain.



Install the safety flange O-ring.

What to Stock

Most manufacturers package repair parts in “repair kits,” including all of the parts necessary to make a certain repair. However, because I don’t know your system, I’m not going to pretend I know what to tell you to keep on the shelf. For instance, if you are located close to a distributor who sells and stocks parts for your hydrants, you may want to stock very little yourself. In case you aren’t lucky enough to live close to a distributor, you at least should have, traffic repair kits, if you have hydrants with this breakaway feature, a seals and O-ring kit or two, and a couple of seats.

When possible, it is always better to have the manufacturer’s representative advise you as to the correct stock of repair parts, grease, oil, or anything else you may need. A particular repair item that most of us never seem to have is an extension kit, which is used to raise a hydrant after the ground around it has been raised. No one would consider a hydrant accessible if its nozzles were resting on the ground.

Recordkeeping

A good O&M program is only as good as the records you keep. Start by assigning a number to each hydrant. And, if you have a distribution map of your system, note the location of each hydrant by number. In addition, the record for each hydrant should include all pertinent information, such as location, make and model, size and number of nozzles, thread type, flow rates, size and material of the main line, and maintenance history. A great source for all sorts of recordkeeping forms relating to hydrant O&M is in the *AWWA Manual of Water Supply Practices, “Installation, Field Testing and Maintenance of Fire Hydrants.”* Not only is this publication a good source of recordkeeping forms, it also is one of the most comprehensive guides to fire hydrant O&M. I have worn out more than one copy and highly recommend it.

Larry Rader has more than 25 years in the water and wastewater industry. When he isn’t working on water and wastewater problems, he likes to play his banjo with an “Old Time” music group in his hometown of Beverly, West Virginia. If you have a question for Rader, he can be reached through e-mail at lrader@meer.net.



National Drinking Water Clearinghouse
West Virginia University
PO. Box 6064
Morgantown, WV 26506



National Environmental Services Center



An Equal Opportunity/Affirmative Action Institution