



Mound Systems

Project funded by the U.S. Environmental Protection Agency under Assistance Agreement No. CX824652

Introduction

A mound system is a technology used for treating and disposing of domestic wastewater in areas unsuited for conventional septic tank soil absorption systems. Originally developed in North Dakota in the late 1940s, the mound was then known as the NODAK disposal system. When these systems were monitored, however, it was discovered that the pea gravel media were too coarse to provide adequate treatment. This and other limitations were overcome by design changes such as: 1) leaving the topsoil in place but plowing it before placement of the fill, 2) using a coarse sand fill meeting grain size distribution specifications, and 3) using pressure to uniformly distribute the effluent over the seepage area.

The basic mound system in use today was developed at the University of Wisconsin-Madison in the early 1970s, and although there are now many different mound designs in use, this fact sheet will focus on the Wisconsin design. The Wisconsin mound has been widely accepted and incorporated in many state regulations.

Mounds are pressure-dosed sand filters that discharge directly to natural soil. They lie above the soil surface and are designed to overcome site restrictions such as:

- slow or fast permeability soils,
- shallow soil cover over creviced or porous bedrock, and
- a high water table.

The main purpose of a mound system is to provide sufficient additional treatment capacity to that of the natural environment to produce an effluent equivalent to, or better than, a conventional onsite disposal system.

Process Description

The three principal components of a mound system are a pretreatment unit(s), dosing (pumping) chamber, and the elevated mound. See Figure 1 on page 2 for an illustration.

The pretreatment unit is most often a septic tank, which removes settleable and floatable solids. The septic tank should also contain a filter to remove additional filterable solids. The dosing chamber follows

the septic tank and normally contains a pump that distributes the septic tank effluent under pressure uniformly over the media. If there is sufficient grade (i.e., the mound is downslope from the septic tank), a siphon may be used instead of the pump.

The mound is made up of a soil cover that can support vegetation and a fabric-covered coarse gravel aggregate in which a network of small diameter perforated pipe is placed. The network of perforated pipe is designed to distribute the effluent evenly through the aggregate and onto the sand media, where the effluent is filtered and passes into the plowed basal area.

Treatment occurs through physical, biological, and chemical means as the wastewater filters down through the sand and the natural soil that is present.

Advantages and Disadvantages

Listed below are some advantages and disadvantages of mound systems when compared to other alternative onsite systems:

Advantages

- The mound system enables use of land that would otherwise be unsuitable for in-ground or at-grade onsite systems.
- The natural soil utilized in a mound system is usually the top layer, which is typically the most permeable.
- A mound system does not have a direct discharge to a ditch, stream, or other body of water.
- If care is taken, construction damage can be minimized since there is little excavation required in the mound area.
- Mounds can be utilized in most climates.

Disadvantages

- Construction costs are typically much higher than those of conventional systems.
- Since there is usually limited permeable topsoil available at mound system sites, extreme care must be taken not to damage this layer with construction equipment.
- The location of the mound may affect drainage patterns and limit land use options.
- The mound may have to be partially

This fact sheet was developed by Clement Solomon, Peter Casey, Colleen Mackne, and Andrew Lake.

©1998 by the National Small Flows Clearinghouse

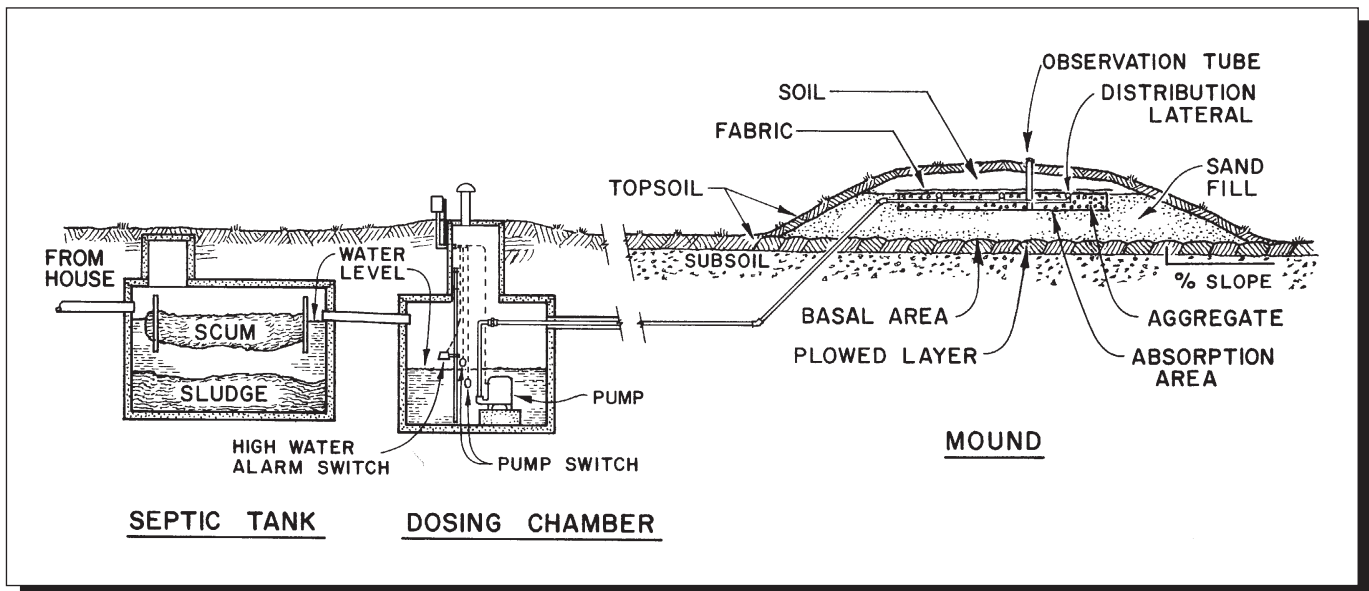

Figure 1: Schematic of a Wisconsin Mound System

Source: Converse and Tyler (1987a), copyright © 1987 by the American Society of Agricultural Engineers, reprinted with permission

rebuilt if seepage or leakage occurs.

- All systems require pumps or siphons.
- Mounds may not be aesthetically pleasing in some cases.

Siting and Design

Two factors that determine the size and configuration of a mound are how the effluent moves away and the rate at which it moves away from the system. The prediction of the movement and rate of movement is done from the soil and site information obtained.

A suitable depth of soil is required to treat the effluent before it reaches the limiting condition, such as bedrock, a high water table, or a slowly permeable soil layer. Although the separation distance varies between codes, it is usually between 1 and 4 feet.

Siting and design experience to date at sites suitable for mound systems indicates that absorption systems should be long and narrow and should follow the contour (i.e., level). The more restrictive the site, the narrower and longer the system. Table 1 gives the soil criteria for a Wisconsin mound based on research and field experience.

The high water table is determined by direct observation, interpretation of soil mottling, or other criteria. The bedrock should be classified as crevice, non-crevice semi-permeable, or non-crevice impermeable. This will determine the depth of sand media required.

Loading rates should be based on the soil texture, structure, and consistence, using the percolation test only to confirm morphological interpretations. Percolation tests are used in some jurisdictions to estimate the soil permeability because it is empirically related to the loading rate.

Mounds can be constructed on sites with slopes up to 25%. The slope limitation is primarily for construction safety, because it is difficult to operate equipment and steep slopes pose a construction hazard. From a hydraulic perspective, mounds can be positioned on steep slopes.

In the case of filled sites, fill material is placed on top of the natural soil and may consist of soil textures ranging from sand to clay. Sufficient time must be allowed for the soil structure to stabilize before constructing a system. Many more observations are required for filled areas.

When evaluating the soil loading rate for a mound over an old or failing in-ground system, the soil over the system must be considered to be disturbed, and thus, treated as a filled site. If a mound is to be placed over a large in-ground system, a detailed evaluation of the effluent movement should be done.

Mounds should not be installed in flood plains, drainage ways, or depressions unless flood protection is provided. Another siting consideration is maintaining the horizontal separation distances from water supply wells, surface waters, springs, escarpments, cuts, the boundary of the property, and the building foundation. Sites with trees and large boulders could also make it difficult in preparing the site. Trees should be cut to the ground surface with tilling around stumps. The size of the mound should be increased to provide sufficient soil to

Table 1: Recommended Soil and Site Criteria for the Wisconsin Mound System Based on Research and Field Experience

Parameter	Value
Depth to high water table (permanent or seasonal)	10 in.
Depth to crevice bedrock	2 ft.
Depth to non-crevice bedrock	1 ft.
Permeability of top 10 in.	Moderately low
Site slope	25%
Filled site	Yes ^a
Over old system	Yes ^b
Flood plains	No

^aSuitable according to soil criteria (texture, structure, consistence).

^bThe area and backfill must be treated as fill because it is a disturbed site.

Source: Converse and Tyler (1990), used with permission

accept the effluent when trees and boulders occupy a significant amount of the surface area.

The actual design of a mound system consists of estimating the sand fill loading rate, soil (basal) loading rate, and the linear loading rate. Once these values are established, the mound can be sized for the site. The final step would be to design the effluent distribution network and the pumping system.

Performance

One factor that determines good performance is the selection of sand fill material. A suitable sand is one that can be loaded at a reasonable rate and can adequately treat the wastewater. Suitable sand should contain 20% or less material greater than 2.0 mm and 5% or less finer than 0.053 mm. It should also have a size distribution that meets certain sieve analysis specifications, ASTM C-33 specifications, or meets limits for effective diameter and coefficient of uniformity.

The successful performance of a mound system is also dependent on design factors. For design of residential mounds, the daily wastewater volume is determined by the number of bedrooms in a house. Typical design flow requirements for individual homes are up to 150 gallons per day (gpd) per bedroom. Design specifications for mound systems are usually the same for both large and small flows for typical domestic septic tank effluent. Higher strength wastes must be pretreated to the levels of domestic septic tank effluent, or lower loading rates may be applied.

In Wisconsin, the success rate of the mound system is over 95%, which is due to their emphasis on siting, design, and construction.

Years of monitoring the performance of mound systems have shown that mounds can consistently and effectively treat and dispose of wastewater. Studies have shown evidence that some nitrogen removal does occur in mound systems when approximately 2 feet of natural unsaturated soil is below the fill material.

Application

Mound Systems in Wisconsin (State-Wide)

Using a relatively conservative soil criteria, many states have accepted the Wisconsin mound system as an alternative when conventional in-ground trenches and beds are not suitable. The Wisconsin mound system has evolved into a viable onsite system for the treatment of wastewater from individual, commercial, and community systems by overcoming some of the site limitations and meeting code requirements and guidelines.

In 1978, an experimental study was initiated to evaluate soil/site limitations for the Wisconsin mound (see Converse and Tyler, 1987a). The objectives of this research study were to determine whether the existing soil/site limitations on mounds were too restrictive and to determine the minimum soil/site limitations under which the mounds would perform without affecting public health and the environment. The experimental approach was to design, construct, and evaluate sites with mound systems that currently did not meet code requirements due to failing systems.

The sites selected for this study had to fit the objectives of the research and generate a reasonable amount of wastewater for

the mound. The sites selected had to have: 1) fill soil placed over natural soil, 2) a high water table where the seasonal high water table level was less than 60 cm below the ground surface, 3) slowly permeable soils that were rated slower than moderately permeable soils, 4) steep slopes greater than 12%, 5) mounds over existing failing systems, or 6) a combination of the above.

Over 40 experimental mounds were constructed between 1979 and 1983 on sites that did not meet the code requirements; 11 of these mounds are described in detail in this study. Site evaluations were done by certified soil scientists, plans prepared by designers were reviewed and approved by the state, and licensed contractors installed the systems with inspections by county sanitarians during construction.

The study concluded that the overall performance of the mounds was very good. The systems functioned satisfactorily on filled sites, on sites with a high water table (seasonal water table 25 to 30 cm from the ground surface), on steep slope sites (up to 20 to 25%), on sites with slowly permeable soil, and on top of failing systems. Leakage occurred at the toe of the mound on some sites during extremely wet conditions, but the effluent quality was good, with fecal counts generally less than 10 colonies per 100 mL in saturated toe effluent. It was found that Wisconsin mound systems can be constructed on difficult sites if the system is designed using linear loading rates, which are established based on the horizontal and vertical acceptance rates of the soil for each system.

Mound System in Wisconsin

Expansion of a Wisconsin firm's mound system in 1978, resulted in a clogging and seepage problem. The system was originally built to handle 65 employees at 750 gpd and was now serving a staff of 165. This expansion created a failure of the mound system due to hydraulic overload. To solve this problem, the mound system was expanded and a water conservation program was initiated. The expansion of the mound increased the hydraulic capacity to 2,600 gpd (see Otis, 1981).

In November 1979, the mound system failed again—this time due to a biological clogging mat. The clogging mat was removed by using 450 gallons of a 10% solution of hydrogen peroxide. The mound system was operating successfully within 2 days. However, further research indicates that hydrogen peroxide may reduce the soil infiltration rate, and thus, may not be an effective procedure.

A third failure occurred in January 1980, again due to hydraulic overload. The firm had expanded its employee base to 215 employees, with an average daily flow of 3,000 gpd. There was no room available to expand the mound system itself, so the firm redesigned the pumping chamber to avoid large peak flows, allowing the mound system to receive optimum dosing without failure.

Operation and Maintenance

The septic tank and dosing chamber should be checked for sludge and scum buildup and pumped as needed to avoid carryover of solids into the mound. Screens or filters can be used to prevent large solids from escaping the septic tank. The dosing chamber, pump, and floats should be checked annually and replaced or repaired as necessary. It is critical that the septic tank and dosing chamber be watertight. In addition, electrical

parts and conduits must be checked for corrosion. Flushing of the laterals annually is recommended.

When a mound system is properly installed and maintained, it should last for a long period of time. In general, the maintenance required for mounds is minimal. However, as with any system, poor maintenance could lead to system failure. Possible problems that can occur in mound systems include:

- ponding in the absorption area of the mound;
- seepage out of the side or toe of the mound;
- spongy areas developing on the side, top, or toe of the mound; and
- clogging of the distribution system.

Listed below are various practices that can be used to reduce the possibility of failure in a mound system:

- installing water-saving devices to reduce the possibility of hydraulic overload to the system;
- calibrating pumps and utilizing event counters and running time meters;
- diverting surface water and roof drainage away from the mound;
- preventing traffic on the mound area;
- installing inspection tubes in the mound to check for ponding;
- keeping deep-rooted plants (shrubs and trees) off the mound; and
- planting grass on the mound surface to prevent erosion.

Follow all instructions recommended by the manufacturer. All equipment must be tested and calibrated as recommended by the equipment manufacturer. A routine operation and maintenance (O&M) schedule should be developed and followed for any mound system.

Table 2: Typical Cost Estimate for a Mound System (Single Home)

Item	Cost (\$)
<u>Capital Costs</u>	
Construction costs	
Septic tank	1,000
Dosing chamber (includes pump and controls)	2,000
Mound structure	6,000
Total Construction Costs	9,000
Non-component costs	
Site evaluation	500
Permits	250
<u>Annual O&M Costs</u>	
Labor @ \$20/hr.	20 per year
Power @ 8 cents/kWh	35 per year
Septic tank pumping	75 to 150 every 3 years

Data supplied by Ayres Associates, Inc., Madison, Wisconsin (1997)

Cost

The cost of a mound system is dependent on the contractor, the manufacturers, the site, and the characteristics of the wastewater. Table 2 lists some typical capital and O&M costs for a mound system serving a three-bedroom single home at a flow rate of 450 gpd (150 gallons per bedroom). Septic tank

costs were estimated at \$1 per treated gallon. It should be noted however, that costs will vary from site to site. To keep construction costs to a minimum, use locally available materials of good quality.

References

- Converse, J. C. and E. J. Tyler. 1987a. "On-Site Wastewater Treatment Using Wisconsin Mounds on Difficult Sites." "Transactions of the ASAE." 1987. American Society of Agricultural Engineers. vol. 30. no. 2. pp. 362-368.
- Converse, J. C. and E. J. Tyler. 1987b. "Inspecting and Trouble Shooting Wisconsin Mounds." Small Scale Waste Management Project. University of Wisconsin-Madison. Madison, Wisconsin.
- Converse, J. C. and E. J. Tyler. January 1990. *Wisconsin Mound Soil Absorption System Siting, Design, and Construction Manual*. Small Scale Waste Management Project. University of Wisconsin-Madison. Madison, Wisconsin.
- Otis, R. J. 1981. "Rehabilitation of a Mound System." On-Site Sewage Treatment: Proceedings of the Third National Symposium on Individual and Small Community Sewage Treatment. American Society of Agricultural Engineers. St. Joseph, Michigan.
- — —. 1983. *Subsurface Soil Absorption of Wastewater Mound Systems*. Ayres Associates, Inc. Madison, Wisconsin.
- U.S. Environmental Protection Agency (EPA). 1980. *Design Manual: Onsite Wastewater Treatment and Disposal Systems*. EPA Office of Water. EPA Municipal Environmental Research Laboratory. Cincinnati, Ohio. EPA 625/1-80-012.

The mention of trade names or commercial products does not constitute endorsement or recommendation for use by the National Environmental Services Center (NESC) or U.S. EPA.

For more information on mound systems contact the NESC at West Virginia University, Morgantown, WV 26506. Phone: (304) 293-4191. Web site: <http://www.nesc.wvu.edu>.